



Food Machinery Component Guide



NTN Food Machinery Components

As customer needs for food preparation have become increasingly diverse, demands regarding the taste, price, and variety of food have become more stringent. A wide variety of dedicated food-processing machines have been developed to deal with this trend and to contribute to the design of more advanced food-processing centers.

NTN offers a full line of easy-to-use mechanical components optimized for food processing machinery. Significantly, they incorporate hygienic design to allow for easy washing and effectively prevent bacteria propagation. As well, they are made of safe materials that comply with the USDA (U.S. Department of Agriculture) and other food standards.

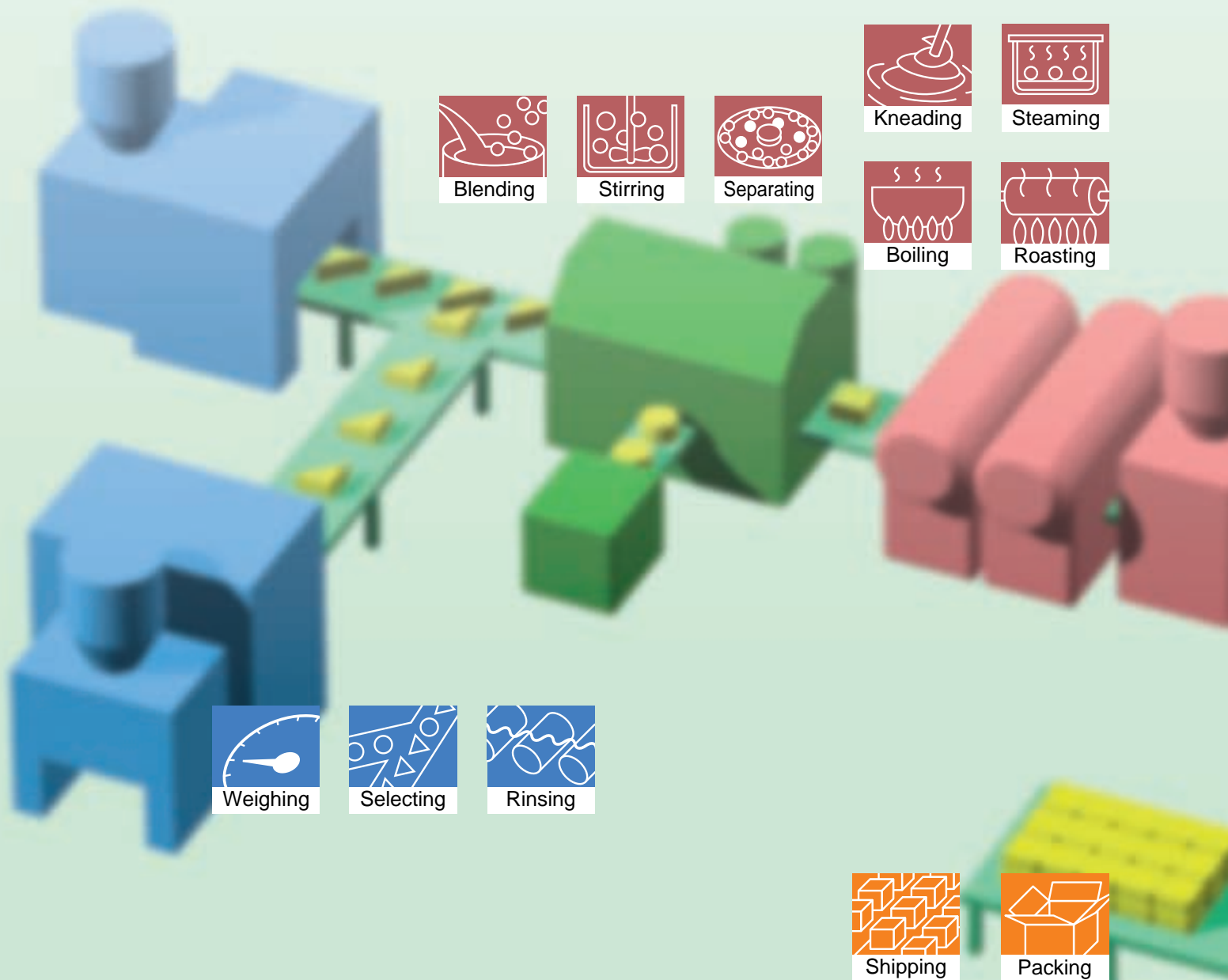

Page



3

Rolling Bearings & Bearing Units

These unique products embody optimal combinations of stainless steel, engineered plastic, and special grease. Ideal for food processing machinery, they take advantage of the basic features of rolling bearings.

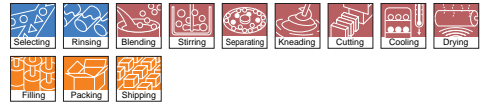

11

Precision Resins (BEAREE products)

This product group covers a wide range of food processing applications. BEAREE products are made from fluorine resin-based super engineered plastic and sliding elastomer. These products are available as plain bearings, seals, and blades.



13

Parts Feeders

NTN parts feeders ensure hygienic environments while accommodating the essential functions of automatic food processing lines - storage, alignment, and supply.

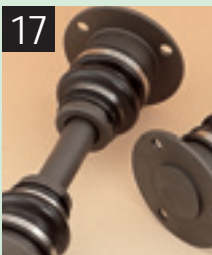

17

Constant Velocity Joints

NTN constant velocity joints smoothly transmit revolution and even accommodate large operating angles and offsets across shafts. Moreover, they provide extremely high durability.



19

Feedscrews

NTN feedscrews efficiently convert rotary motion into linear motion by combining polyimide.

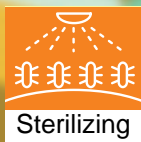
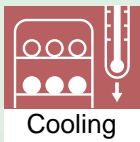



Rolling Bearings & Bearing Units



Characteristics of Rolling Bearings for Food Processing Machinery

Characteristics		Lubricant type	Food-grade solid grease	Food-grade general-purpose grease	General-purpose solid grease	Resin rolling bearing
		Symbol	LP06	L596	LP03	—
Permissible operating temperature (at bearing outer ring)			-10~100°C (80°C max. for continuous operation)	-20~110°C	-20~80°C (60°C max. for continuous operation)	-20~80°C (60°C max. for continuous operation)
Applicable bearing	Standard product SUJ2		Not permissible	Permissible	Permissible	PPS or polyimide
	Stainless steel SUS440C		Permissible	Permissible	Permissible	
Cost	Short-term		△	◎	△	△
	Long-term (including maintenance)		◎	×	◎	○
Lubricant life			◎	○	◎	○
Oil loss or leakage			◎	△	◎	◎
Bearing torque			Relatively low	Standard	Low	Low
Food safety			◎	◎	○	◎

① "Spot-pack" prelubrication is provided with bearings with solid grease.

◎Excellent ○Good △Fair ×Poor

② Applicable bearing types are deep-groove ball bearings and ball bearings for bearing units.

③ Contact with organic solvent, wash oil or other chemicals can degrade the lubricating performance of solid grease.



Selecting Bearing Units/Food Machinery Bearing Housings

Bearing housing specifications	Corrosion resistance	Food safety	Cost	
			Short-term	Long-term
Standard painted type	×	×	◎	×
Resin (plastic)	◎	◎	△	○
Stainless steel	◎	◎	×	◎

◎Excellent ○Good △Fair ×Poor

3.1 Bearings with solid grease

Solid grease is a unique solid bearing lubricant that essentially comprises lubricating grease and super molecular weight polyethylene. Before being packed into a bearing, it resembles ordinary grease. However, once heated and cooled, it solidifies and takes on a solid resin-like appearance. Spot packing is the standard lubricant prefill system. The cage is provided with grease at several spots.

a) Bearings with solid grease for general use (P-03)

- **Features**

- (1) More resistant to centrifugal force-induced leakage.
- (2) Fouling from grease leaks on or around the bearing is positively prevented.
- (3) Water does not emulsify the grease or cause the grease to leak. Thus, the grease has a longer lubricating life.
- (4) Unlike ordinary grease, bearings with solid grease exhibits virtually no stirring drag and therefore contributes to lower bearing torque.

- **Permissible operating temperature range and speed**

Temperature at bearing outer ring:

Use the bearing in a temperature range of -20°C to 80°C (60°C max. for continuous operation).

Permissible dn value: 120 000

$[dn = \text{bearing bore diameter } d(\text{mm}) \times \text{operating speed } n(\text{min}^{-1})]$

- **Applicable bearings**

Ball bearings for bearing units, with a maximum bore diameter of 140 mm (models UC, UK, AS, CS)
Grease code: LP03

b) Bearings with solid grease for food machinery (P-06)

- **Features**

In addition to the advantages of the general-use bearings with solid grease (P-03) as mentioned in a) above, bearings with solid grease type P-06 boasts a high degree of safety because its heat-solidifying grease for food machinery is composed of food-grade lubricating grease that complies with the USDA's H-1 standard (permitting contact with food) and super molecular weight polyethylene approved according to an FDA (US Food and Drug Administration) standard.

- **Permissible operating temperature range and speed**

Temperature at bearing outer ring:

Use the bearing in a temperature range of -10 to 100°C (80°C max. for continuous operation).

Permissible dn value: 100 000

$[dn = \text{bearing bore diameter } d(\text{mm}) \times \text{operating speed } n(\text{min}^{-1})]$

- **Applicable bearings**

Ball bearings for stainless steel bearing units, with a maximum bore diameter of 50 mm (model UC)
Grease code: LP06



Bearings with solid grease for food machinery



Prelubricated bearing for food machinery

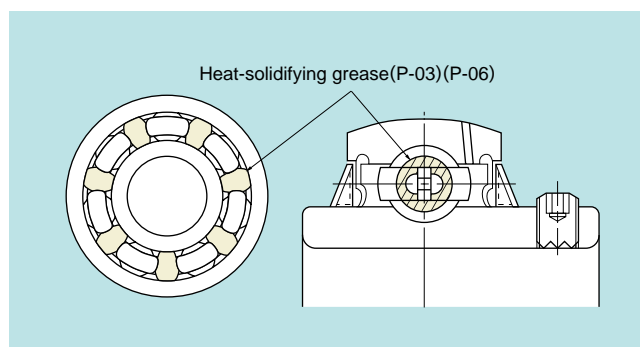

Stainless steel bearings with solid grease

3.2 Prelubricated bearings for food machinery

- **Features**

This bearing type provides a high degree of safety, as it is filled with lubricating grease compliant with the USDA's H-1 standard.

- **Permissible operating temperature range**

$-20^{\circ}\text{C} \sim 110^{\circ}\text{C}$.

Note : Heat-resistant bearing can be used up to 140°C .

- **Applicable bearings**

Ball bearings for stainless steel bearing units, with a maximum bore diameter of 140 mm (all models).
Grease code: L596



Grease

Bearings with solid grease for food machinery



Bearings with solid grease for general use

**Bearings with solid grease for food machinery/prelubricated bearing for food machinery/
bearings with solid grease for general use**

4.1 Features

NTN stainless series bearing units comprise a stainless steel ball bearing and a stainless steel bearing housing, which provide much greater corrosion resistance than standard cast iron bearing units.

- **Bearings with solid grease for food machinery**

This ball bearing unit employs food-grade heat-solidifying grease for improved safety and minimum lubricant leakage. This reduces the possibility of environmental contamination. Another hygienic feature of this bearing unit is the smooth cast surface of its housing, which attracts minimal amounts of foreign matter.

- **Prelubricated bearing for food machinery**

Because the ball bearing employs food-grade grease complying with the USDA's H-1 standard (permitting contact with food), this bearing unit features outstanding safety.

- **Bearings with solid grease for general use**

This ball bearing unit employs general-purpose heat-solidifying grease for minimized lubricant leakage. This reduces the possibility of environmental contamination. Another hygienic feature of this bearing unit is the smooth cast surface of its housing, which attracts minimal amounts of foreign matter.

4.2 Materials

Parts		Materials
	Bearing ring	Martensitic stainless steel (SUS440C or equivalent)
	Rolling element	Martensitic stainless steel (SUS440C)
Bearing	Slinger/cage	Austenitic stainless steel (SUS304)
	Rubber seal	Nitrile rubber
	W-point setscrew	Martensitic stainless steel (SUS410)
Bearing housing		Austenitic stainless steel (SCS13)

4.3 Lubricants, operating temperature range, and speed

Bearing	Lubricant	Permissible operating temperature range (at outer ring)	Permissible speed
Bearings with solid grease for food machinery	Heat-solidifying grease (P-06) ^①	-10°C~+100°C (80°C max. for continuous operation)	Permissible dn value : 100 000 ^③
Prelubricated bearing for food machinery	CALTEX FM grease EP2 ^②	-20°C~+110°C	Permissible dn value : 120 000 ^③
Bearings with solid grease for general use	Heat-solidifying grease (P-03)	-20°C~+ 80°C (60°C max. for continuous operation)	

① Solid lubricant formulated with grease complying with the USDA's H-1 standard and super molecular weight polyethylene approved according to standards of the FDA.

② Grease satisfying the USDA's H-1 standard

③ dn =bearing bore diameter d (mm) × operating speed n (min⁻¹)

4.4 Corrosion resistance

Material	Conditions	In air		* In water		In acid	
		Ventilated	Humid	Natural water	Seawater	Nitric acid	Hydrochloric acid
Martensitic stainless steel	SUS440C, SUS410	○	△	△	▲	▲	×
Austenitic stainless steel	SUS304, SCS13	◎	◎	◎	○	◎	△
High carbon chromium bearing steel	SUJ2	△	▲	▲	×	×	×
Carbon steel/cast iron		▲	×	×	×	×	×

* Not recommended for use in water

◎Excellent ○Good △Fair ▲Poor ×Unacceptable

4.5 Applicable bearings (unit designations)

Bearing	Pillow block bearing units	Rhombic flanged housing bearing units
Bearings with solid grease for food machinery ^①	F-UCPM204/LP06~F-UCPM210/LP06	F-UCFM204/LP06~F-UCFM210/LP06
Prelubricated bearing for food machinery	F-UCPM204/L596~F-UCPM210/L596	F-UCFM204/L596~F-UCFM210/L596
Bearings with solid grease for general use	F-UCPM204/LP03~F-UCPM210/LP03	F-UCFM204/LP03~F-UCFM210/LP03

① For safety reasons, solid lubricants lack anti-rusting agents. Therefore, only bearings made of stainless steel are applicable.

4.6 Applications

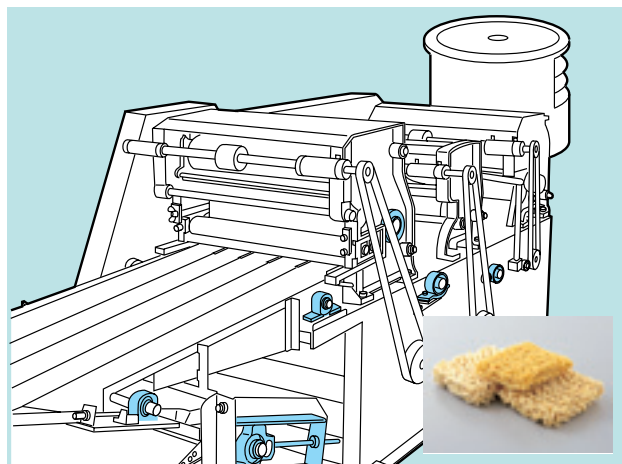

Noodle machine (instant noodles & soups)

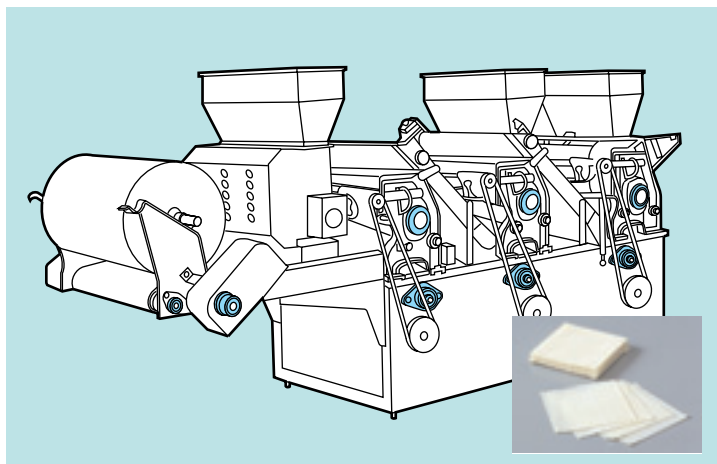

Automated pasta-wrapping line



**Bearings with solid grese for food machinery/prelubricated bearings for food machinery/
bearings with solid grease for general use**

5.1 Features

NTN plastic series bearing units combine a stainless steel ball bearing and a resin bearing housing. They feature hygienic safety as their bearing housings are free of peeling paint and rusting.

- **Bearings with solid grease for food machinery**

This ball bearing unit employs food-grade heat-solidifying grease for improved safety and minimum lubricant leakage. This reduces the possibility of environmental contamination. As an added safety feature, the housing does not develop peeling paint or rusting.

- **Prelubricated bearings for food machinery**

This bearing unit features outstanding safety thanks to the ball bearing's lubrication with food-grade grease, complying with the USDA's H-1 standard.

- **Bearings with solid grease for general use**

This ball bearing unit employs general-purpose heat-solidifying grease for minimized lubricant leakage. This reduces the possibility of environmental contamination. As an added safety feature, the housing does not develop peeling paint or rusting.

5.2 Materials

Parts		Materials
Bearing	Bearing ring	Martensitic stainless steel (SUS440C or equivalent)
	Rolling element	Martensitic stainless steel (SUS440C)
	Slinger/cage	Austenitic stainless steel (SUS304)
	Rubber seal	Nitrile rubber
	W-point setscrew	Martensitic stainless steel (SUS410)
Bearing housing	Housing proper	Glass fiber-reinforced thermoplastic polyester
	Sleeve for mounting bolt	Austenitic stainless steel (SUS304)
	Mounting nut for grease nipple	Austenitic stainless steel (SUS303)
Cover		Polypropylene
Spare plug		Polyethylene

5.3 Lubricants, operating temperature range, and speed

Bearing	Lubricant	Permissible operating temperature range (at outer ring)	Permissible speed
Bearings with solid grease for food machinery	Heat-solidifying grease (P-06) ^①	-10°C~+ 80°C	Permissible dn value : 100 000 ^③
Prelubricated bearing for food machinery	CALTEX FM grease EP2 ^②	-20°C~+ 80°C	Permissible dn value : 120 000 ^③
Bearings with solid grease for general use	Heat-solidifying grease (P-03)	-20°C~+ 80°C (60°C max. for continuous operation)	

① Solid lubricant formulated with grease complying with the USDA's H-1 standard and super molecular weight polyethylene approved according to standards of the FDA.

② Grease satisfying the USDA's H-1 standard

③ dn =bearing bore diameter d (mm) × operating speed n (min⁻¹)

5.4 Corrosion resistance

Material	Conditions	In air		* In water		In acid	
		Ventilated	Humid	Natural water	Seawater	Nitric acid	Hydrochloric acid
Martensitic stainless steel	SUS440C, SUS410	○	△	△	▲	▲	×
Austenitic stainless steel	SUS303, SUS304	◎	◎	◎	○	◎	△
Thermoplastic polyester resin		◎	◎	◎	◎	▲	○
Polypropylene/polyethylene		◎	◎	◎	◎	○	○
High carbon chromium bearing steel	SUJ2	△	▲	▲	×	×	×
Carbon steel/cast iron		▲	×	×	×	×	×

* Not recommended for use in water

◎Excellent ○Good △Fair ▲Poor ×Unacceptable

5.5 Applicable bearings (unit designations)

Bearing	Pillow block bearing units	Rhombic flanged housing bearing units
Bearings with solid grease for food machinery	F-UCPR204/LP06~F-UCPR208/LP06	F-UCFLR204/LP06~F-UCFLR208/LP06
Prelubricated bearing for food machinery	F-UCPR204/L596~F-UCPR208/L596	F-UCFLR204/L596~F-UCFLR208/L596
Bearings with solid grease for general use	F-UCPR204/LP03~F-UCPR208/LP03	F-UCFLR204/LP03~F-UCFLR208/LP03

5.6 Applications

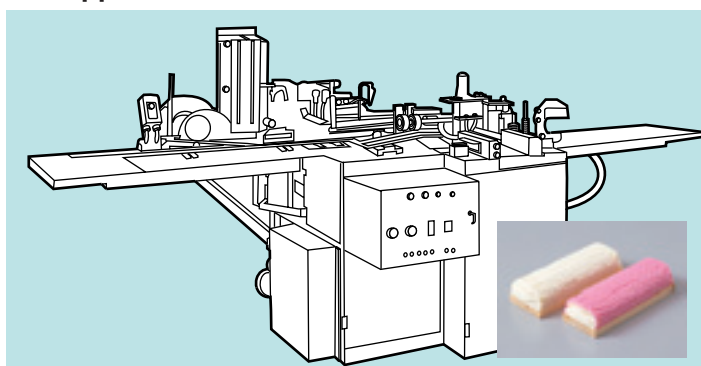

Automatic packing machine for Japanese-style fish cake

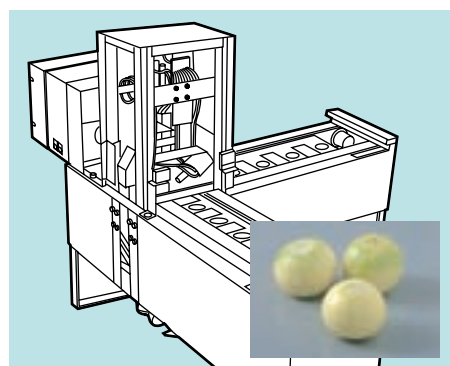

Automatic onion skinning machine

Triple-sealed bearings with secure dustproofing / waterproofing

Provides a longer service life even when exposed to heavy airborne dust and splashing water.



6.1 Features

- **Better dustproofing and waterproofing ensures longer bearing life.**

The triple-sealed bearing is provided with a triple-lipped bearing seal. The special seal offers reliable dustproofing and waterproofing superior to those of standard bearings for bearing units. It therefore ensures longer service life even under conditions of heavy airborne dust and dirty splashing water.

- **Reduces maintenance cost.**

With a longer bearing life than ordinary bearings used in unit configurations, these bearings have longer maintenance intervals, greatly reduced maintenance costs (for inspection, relubrication, replacement, etc.), and increased productivity of machines.

- **Decreases price of bearing unit and allows for much more compact machinery.**

Under certain operating conditions, the triple-sealed bearing unit can replace conventional covered bearing units, greatly decreasing the cost of bearing units. Furthermore, if the cover is not needed, machinery can be made much more compact.

- **Balled setscrew ensures secure fastening**

The triple-sealed bearing is mounted on the shaft with NTN's unique balled setscrew, which has an embedded ball in its tip. This setscrew boasts much greater resistance to loosening than serrated or cup-point setscrews, and does not readily loosen due to vibration or impact.

- **Interchangeability**

The triple-sealed bearing unit conforms to the JIS standard for UC-type bearings. It can be readily used as a relubricable bearing, and can replace NTN's conventional bearing unit and other manufacturers' products. It can therefore easily be used to replace existing bearing units during machinery maintenance.

6.2 Construction

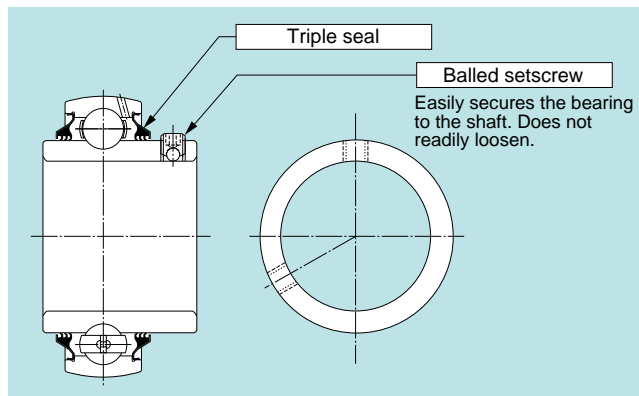

Triple-sealed bearing

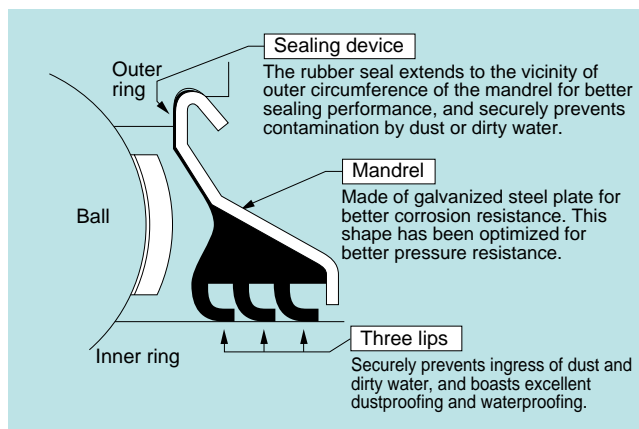

Triple-seal

6.3 Permissible operating temperature range and speed

Use the triple-sealed bearing within the temperature range of -15 to 100°C .

Permissible dn value: 36 000

$[dn = \text{bearing bore diameter } d \text{ (mm)} \times \text{operating speed } n \text{ (min}^{-1}\text{)}]$

6.4 Applicable bearings

Ball bearings for bearing units, with a maximum bore diameter of 90 mm.

UC201D1LLJ~UC218D1LLJ

6.5 Typical applications

Triple-sealed bearing units are suitable for machines used in locations subjected to splashing water and heavy dust, such as bread-making/confectionery machines, noodle-making machines, fish-processing machines, flour mills, rice/barley pearling mills, beverage processing machines, brewing machines, and bottle-making machines.

6.6 Special specification bearing units

The standard products of this series are prelubricated with lithium mineral grease. Contact NTN Engineering for information on optional bearings, such as those containing Polyube (heat-solidifying grease) or food-grade grease, and stainless steel bearings.

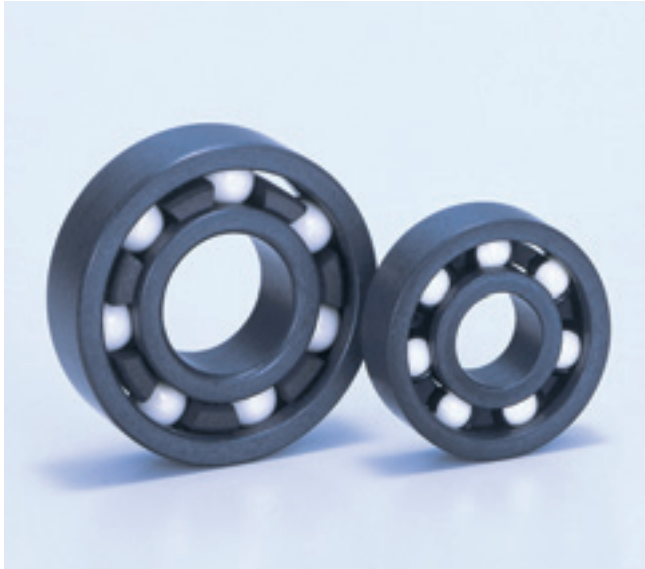

7.1 Features

Standard bearings cannot be used in environments where they will be exposed to water or liquid chemicals. In contrast, NTN resin rolling bearings can operate without relubrication, at a lower torque in such environments because their inner and outer rings, balls, and cage are made of unique corrosion-proof self-lubricating materials.

Note, however, these bearings must be used at a lower load rating and limiting speed because their inner and outer rings are made of resin.

7.2 Materials

Parts	Materials
Inner/outer rings	BEAREE AS5701 (PPS-base), or BEAREE PI 5001 (polyimide-base)
Balls	Glass or ceramic
Cage	Glass fiber reinforced nylon 66 or BEAREE FL3700

7.3 Bearing number and bearing table

Inner/outer ring: BEAREE AS5701,
Cage: Glass fiber reinforced nylon

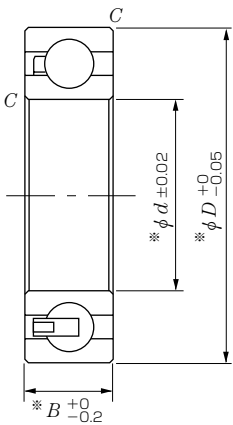

Bearing	Basic load rating (approx.)	Boundary dimensions mm				Mass g (approx.)
		d	D	B	C	
6000	3	10	26	8	0.3	5
6001	3	12	28	8	0.3	6
6002	3	15	32	9	0.3	8
6003	5	17	35	10	0.3	10
6004	6	20	42	12	0.6	17
6200	4	10	30	9	0.3	8
6201	5	12	32	10	0.6	10
6202	6	15	35	11	1.0	12
6203	8	17	40	12	1.0	17
6204	10	20	47	14	1.0	28

Radial internal clearance(mm) : 0.05~0.20

* The dimensional and running accuracy differ from that of standard bearings

7.4 Operation

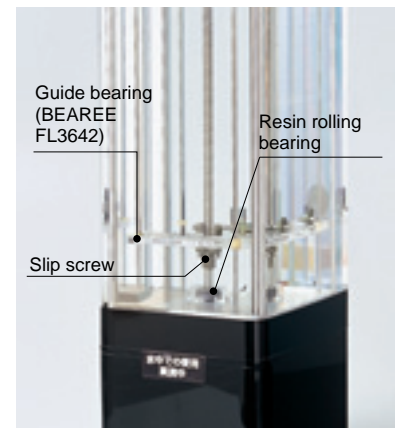

Bearing operation in water

7.5 Typical applications

- Photographic film developing machine (Types #6202 and 6203)**
 Operating conditions: Radial load: max. 0.95 kgf
 Speed: 1000 min⁻¹
 Environment: Developer solution of pH 0.9 to 12
- Aluminum foil forming line (Types UC205 and 206)**
 Operating conditions: Radial load: 13~15 kgf
 Speed: 1 min⁻¹
 Environment: Acidic or water vapor
- Magneto-optical disk sputtering machine (dia. 20×dia. 25×4 mm)**
 Operating conditions: Radial load: 1.0 kgf
 Speed: 120 min⁻¹
 Environment: Vacuum
- Hard disk washing machine**
 Operating conditions: Radial load: 2.0 kgf
 Limiting speed: 400 min⁻¹
 Environment: Pure water

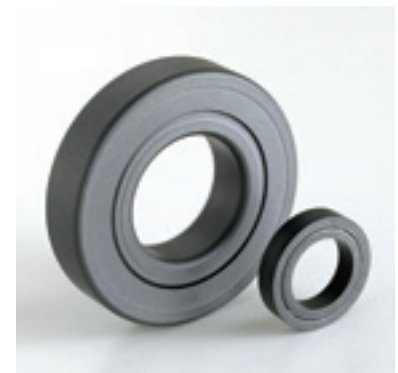

Aromatic thermosetting resin rolling bearings



BEAREE

BEAREE Products Meet Diverse Needs in the Food Machinery Industry.

1. BEAREE satisfies the specification test for synthetic resin utensils, containers, and packaging materials by Japan Food Research Laboratories.
2. It is available in the hygienic colors of white or pale yellow.



BEAREE FL3642 <Fluororesin Series>

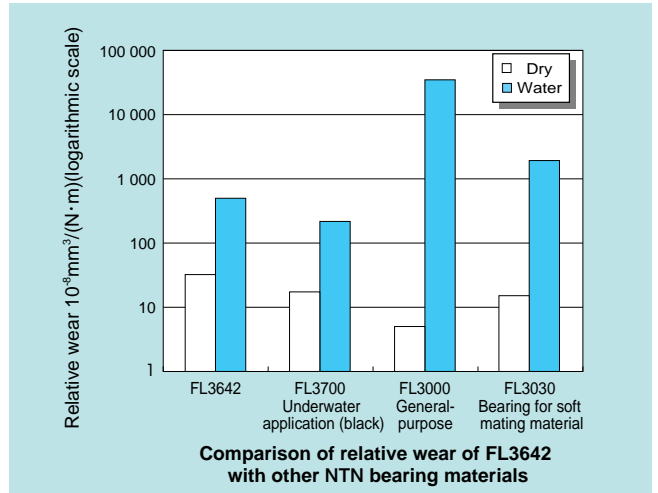

● Time-dependent change in dynamic friction coefficient
 The graphical plot below represents the time-dependent change in the dynamic friction coefficient under the above-mentioned test conditions, either in dry state or with water lubrication.

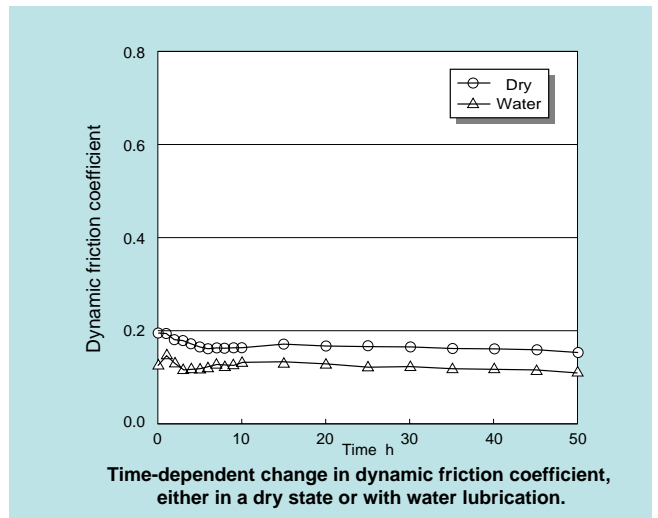

1.1 Features

1. Excellent friction/wear characteristics when not lubricated or when operating in liquid.
2. Higher permissible PV value. Maximum permissible operating temperature is 260°C.
3. Good compatibility with mild steel or stainless steel.
4. Least affected by acid, base, or solvent.

1.2 Sliding characteristics

● Comparison of wear characteristics with various BEAREE products

Wear characteristics of FL3642, either in a dry state or with water lubrication, are compared with those of other BEAREE materials.

- ◆ Test conditions: Thrust tester
- Bearing pressure: 0.98 MPa
- Peripheral speed: 32 m/min
- Mating material: SUS304
- Lubrication: Dry or water
- Test duration: 50 hrs.



Products for food machinery



Other BEAREE materials also satisfy the above specification test, and are used according to the intended applications.

Typical BEAREE materials that satisfy the specification test for synthetic resin containers and packaging materials

Material description	Color	Applications
BEAREE FL 3040	Black	Bearing for soft mating materials
BEAREE FL 3700	Black	Bearing for underwater applications
BEAREE AS 5000	Light brown	General-purpose



3.1 Features

1. Its elasticity ensures an excellent seal.
2. Better friction/wear characteristics than general-purpose fluororubber
3. Maximum continuous operating temperature of 230°C
4. Good compatibility with soft mating materials

3.2 Characteristics of BEAREE ER as a sliding material

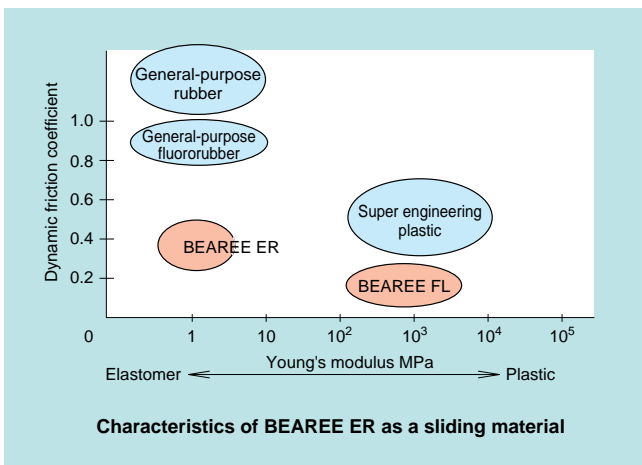

3.3 PV value and relative wear

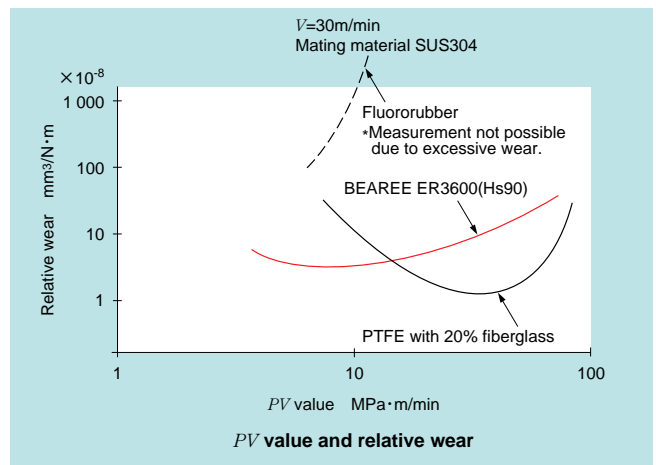

4.1 Features

1. Excellent friction/wear characteristics at lower PV value
2. Excellent impact resistance
3. Very economical

Note: NTN also supplies BEAREE UH300 in rod and pipe forms.

4.2 Typical characteristic values

Specific gravity	Compression creep %	Hardness ①	Tensile strength		Elongation %	Bending strength		Young's modulus in flexure		Water absorption %	Coefficient of linear expansion × 10 ⁻⁵ /°C ②	Max. permissible operating temp. °C
			MPa	kgf/cm ²		MPa	kgf/cm ²	MPa	kgf/cm ²			
0.94	11.0	65	20	200	200	20	200	610	6 100	0.01	20.0	80

① Hardness: Durometer

② Coefficient of linear expansion: Average coefficient in the range from room temperature to 80°C.



Parts Feeders



Functions of Parts Feeders

Parts feeders are generally used for the following:

Storage

Alignment

Supply

The most important task is alignment. Alignment techniques include the attachment alignment system (the most common method) and the use of sensors or image processing systems.

With the attachment alignment system, variously configured lanes and mechanical arrangements are provided in and around the bowl to align the work pieces.

An automatic food processing line can run stably and reliably with a combination of NTN's unique parts feeder and an alignment system optimized for each type of work piece.

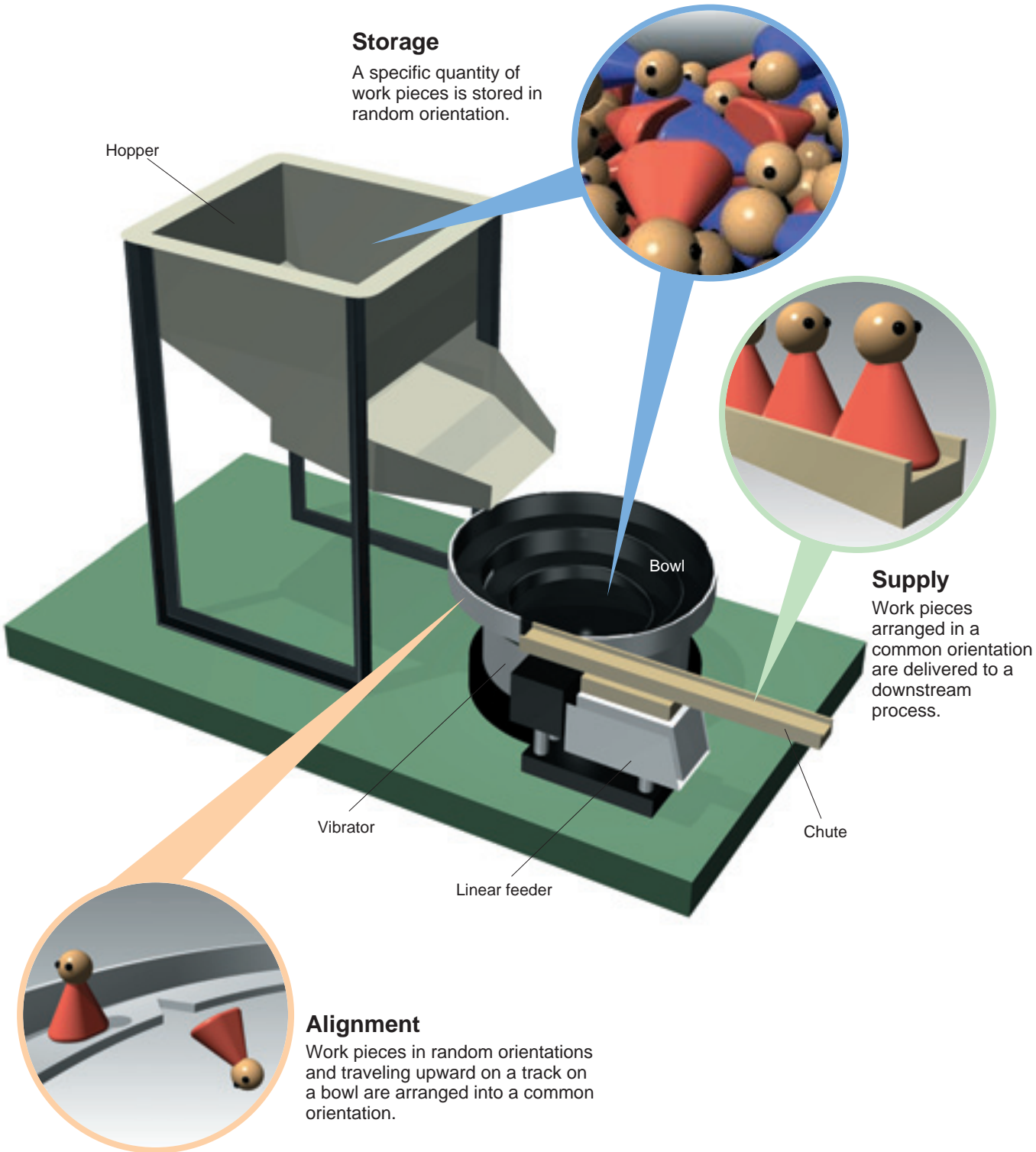

3

Typical Parts Feeder Applications

NTN parts feeders can feed work pieces of various forms and textures, including candy, ice cream, biscuits, dried noodles, and powders.



4

Escapement

● Separation

Individual work pieces are separated from a queue by a cylinder.

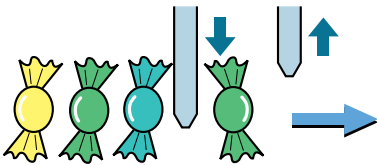

● Combining

Work pieces of different forms, each supplied separately, are mechanically mated.

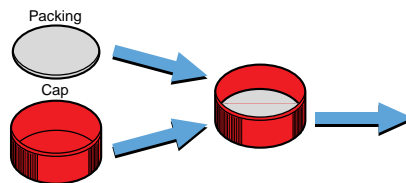

● Lifting

Work pieces are lifted, with their hole used as a guide.

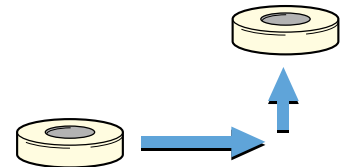

5

Bowl One-touch Clamp

5.1 Features

The bowl can be attached or detached quickly and easily.

5.2 Applications

- When the bowl must be sterilized or washed at regular intervals, for example, on food-processing or medicine-packing lines.
- When the bowl must be replaced frequently to accommodate small-lot, multiple-product manufacturing. (The one-touch clamp feature is most useful when combined with a computerized variable frequency controller.)





■ Work piece: Biscuits

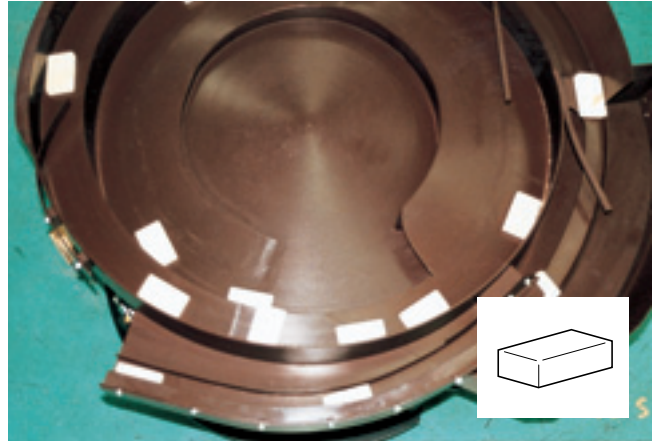

■ Work piece: Rice cakes



■ Work piece: Ice cream (chocolate coating)

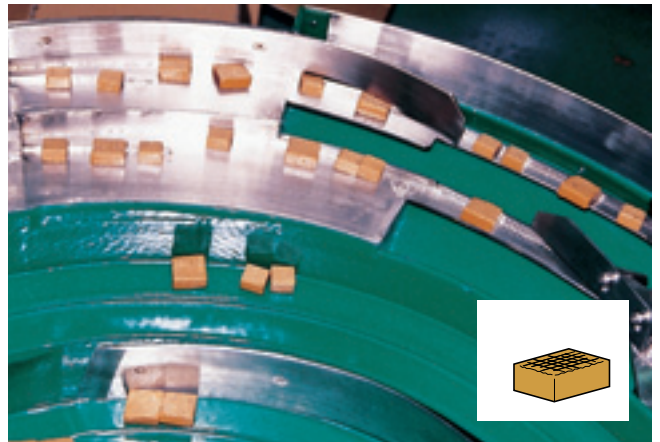

■ Work piece: Caramels



■ Work piece: Candy

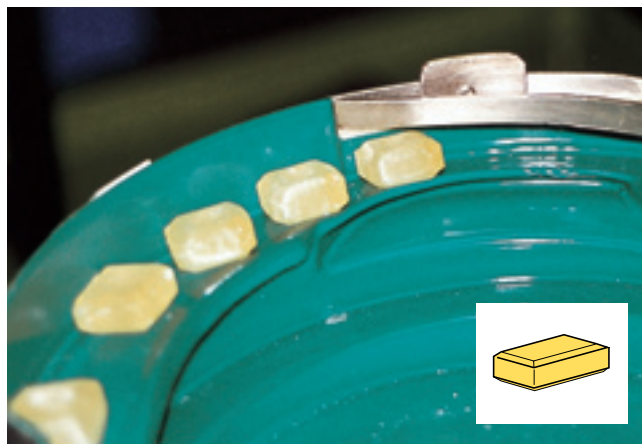



Constant Velocity Joints



Constant Velocity Joints



1.1 Features

- Smooth operation**
 The constant velocity mechanism ensures smooth and quiet rotation.
- Secure sealing**
 The grease is fully contained within a boot, ensuring a clean and hygienic environment.
- Requires no relubrication for a prolonged period.**
 The boot provides a reliable seal that prevents grease leakage and water ingress, ensuring a long period of relubrication-free operation.
- Wide range of variants**
 We offer a wide range of constant velocity joints of various types and sizes. Choose the optimal joint design or configuration to meet the intended application and operating conditions.

1.2 Types and features of constant velocity joint

Type	Model	Joint number	Max. permissible operating angle ^①	Features
Fixed type	Cup type	BJ75C ~BJ225C	25°	Greater permissible operating angle Outstanding sealing performance
	Drum type	BJ75M ~BJ125M		
Sliding type	DOJ flanged type	DOJ 68F~DOJ200F DOJ225F~DOJ625F	20° 8°~10°	Expansion is possible within the joint. Low sliding resistance (expanding resistance)
	TBJ flanged type	TBJ8SF~TBJ60SF	16°~18°	
	TBJ bossed type	TBJ8SB~TBJ60SB		
Coupling type	BC series	BC68~BC200 ^②	5°	No alignment work is needed. Easy mounting.
	TBJ DF series	TBJ8DF~TBJ60DF	8°	
	TBJ DB series	TBJ8DB~TBJ60DB		

① The maximum permissible operating angle is limited by the boot, as well as the number of revolutions and operating conditions of the joint assembly.

② We can manufacture larger joints upon customer request. For details, contact NTN Engineering.

1.3 Type selection flowchart

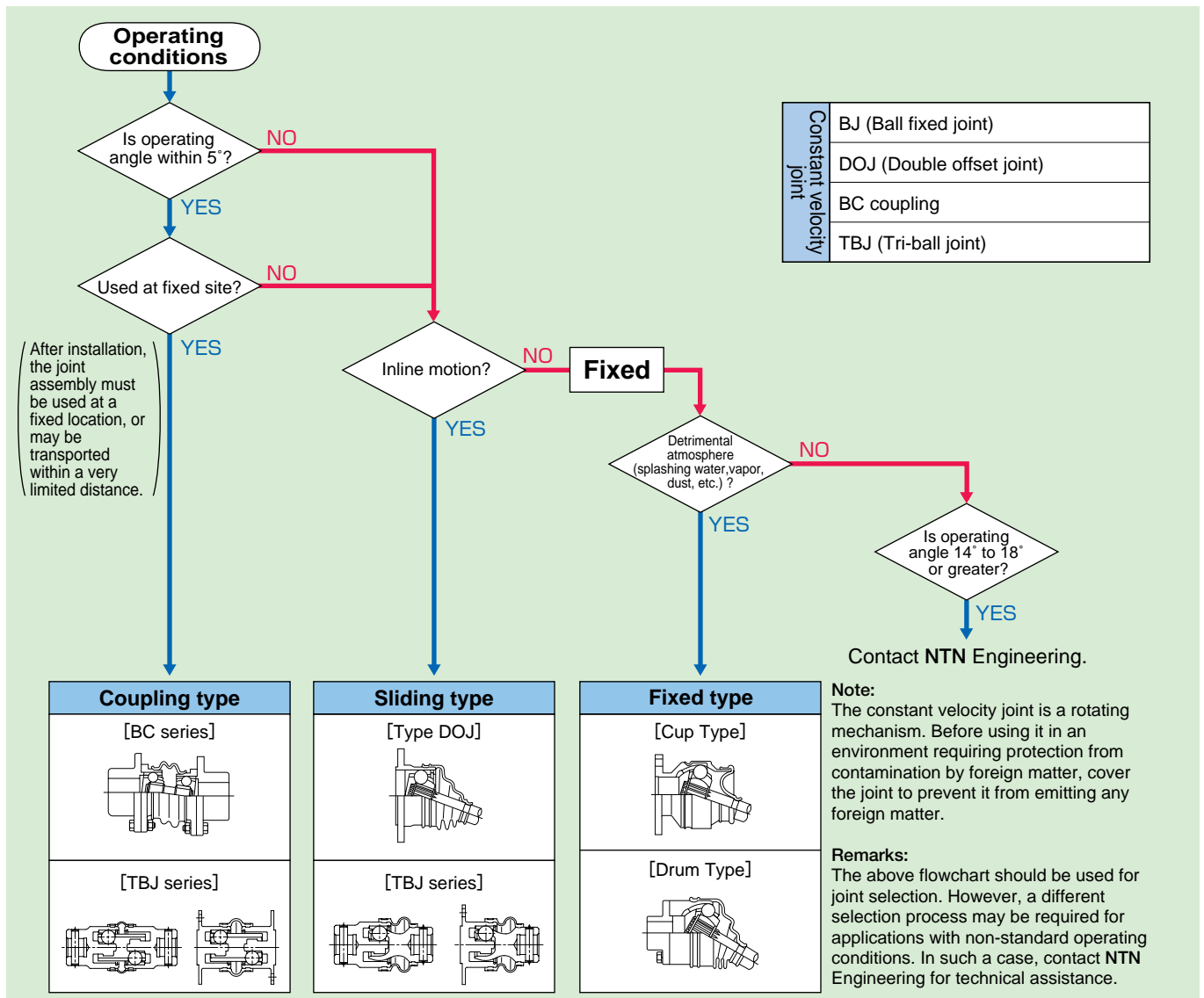

1.4 Typical applications

Canning lines for fish, meat, fruit, beverages, food and delicacies.

Bottling lines for beverages, liquid seasonings, etc.

Packing lines for instant foods/retort-packaged foods.

Rotary drives in bottle-washing machines, labelers, kneading machines, etc.

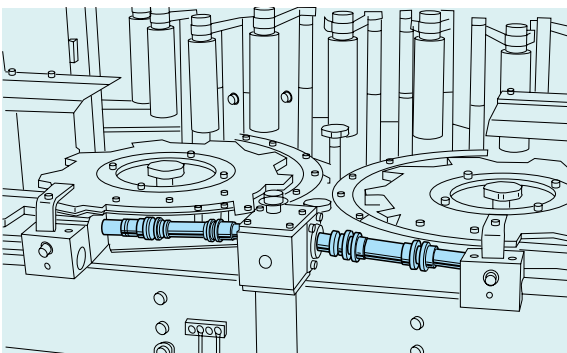

Bottle-washing machine

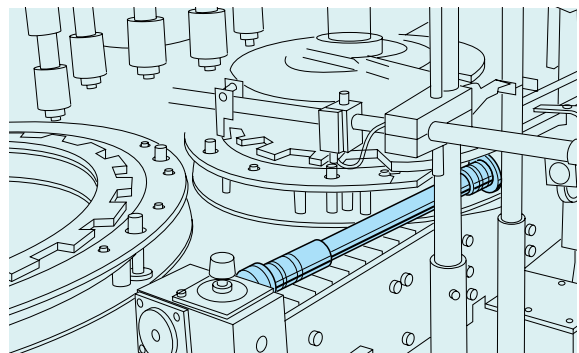

Bottle capping machine



Feedscrews



Miniature Resin Slide Screws



NTN miniature resin slide screws incorporate both BEAREE AS5000 nuts, which feature excellent friction/wear characteristics, and stainless steel threaded shafts.

1.1 Features

- Accommodates a variety of environments.
Lubrication-free, corrosion-resistant, and heat-resistant
- Lower noise than ball screw configurations.
- The low-friction resin nut ensures higher screw efficiency.
- NTN will machine the shaft end to customer specifications.

1.2 Specifications

Type : Single-flanged single nut
 Material/resin nut : AS 5000
 Threaded shaft : SUS304

1.3 Bearing numbers and bearing table

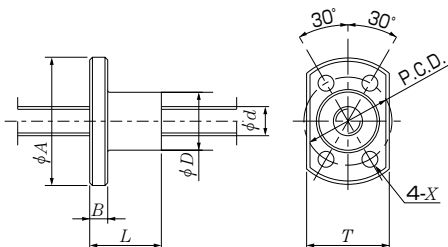
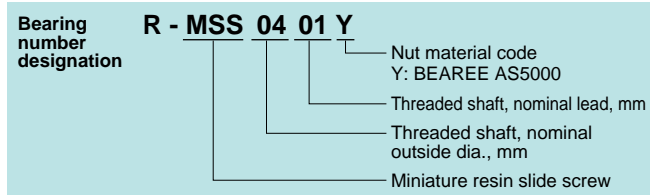

unit : mm

Bearing number	Threaded shaft		Resin nut								Standard shaft length	
	Nominal dia. d	Nominal lead	Outside dia. $D_{\pm 0.02}$	Length L	Flange		Mounting hole		Width across flats T	No. of start		
					A	B	P.C.D.	Hole dia. X	No. of holes			
R - MSS0401Y R - MSS0402Y	4	1 2	10	10	23		23	2.9	4	15	1 2	200
R - MSS0601Y R - MSS0602Y R - MSS0609Y R - MSS0618Y	6	1 2 9 18	12	12	26	3.5	26	3.4		17	1 4	
R - MSS0801Y R - MSS0802Y R - MSS0812Y R - MSS0824Y	8	1 2 12 24	14	12	29	4	26			18	4 6	400
R - MSS1002Y R - MSS1015Y R - MSS1030Y	10	2 15 30	16	16	33	5	33	21		1 4 6	450	
R - MSS1202Y R - MSS1218Y R - MSS1236Y	12	2 18 36	18	16	35		33	22	1 6	500		

